

Experimental investigation and justification of the parameters of the separator of potato heap

Bulgakov V.¹, Adamchuk V.², Ruzhylo Z.³, Holovach I.⁴, Ihnatiev Ye.⁵

^{1,3,4}*National University of Life and Environmental Sciences of Ukraine
15 Heroiv Oborony Str., Kyiv, 03041, Ukraine*

²*NSC «Institute of Mechanization and Electrification of Agriculture»
11 Vokzalna Str., Hlevakha township, Vasylkiv district, Kyiv oblast, 08631, Ukraine*

⁵*Tavria State Agrotechnological University named after Dmytro Motornyi
18B Khmelnytskoho Ave., Melitopol, Zaporizhzhia oblast, 72312, Ukraine*

e-mail: ¹vbulgakov@meta.ua, ²vvadamchuk@gmail.com, ³ruzhylo@nubip.edu.ua, ⁴holovach.iv@gmail.com, ⁵yeven.ihnatiev@tsatu.edu.ua

ORCID: ¹0000-0003-3445-3721, ²0000-0003-0358-7946, ³0000-0003-3582-8687, ⁴0000-0003-1387-4789, ⁵0000-0003-0315-1595

Goal. To justify the rational constructive and kinematic parameters of the new cleaner of potato heap of spiral type based on the results of multi-factor experimental field studies. **Methods.** Methods of correlation and regression analyses and the methods of construction of nomograms were applied for processing and analysis of experimental research. **Results.** A new design is developed of a cleaner of potato heap, which consists of 3 console-located drive coils. It provides an active cleaning surface for the dug heap. It is possible to change the angle of the inclination of the cleaning surface to the horizon, which provides a different intensity of separation of impurities and ensures the movement of tubers in the direction of the conveyor belt. That also contributes to a better dispersal of the heap at the working surface of the cleaner, more intensive destruction of soil lumps, and consequently, to improve screening and reduce clogging of the cleaning coils. An experimental study in the production conditions showed that cleaning of potato tubers from impurities was due to the intensive movement of the heap coils of cantilevered cleaning coil springs. Cleaning coil springs rotate not only with a given angular velocity, but at the same time oscillate their console ends due to the deflection of the longitudinal axis under the weight of the heap in the working area of the cleaner. **Conclusions.** The model of monofactorial experiment is built according to the field experimental studies, statistical processing of the results of which is implemented using Microsoft Excel. Graphic dependencies are built, allowing us to choose rational constructive and kinematic parameters of potato cleaners of spiral type at designing and developing new potato harvesters.

Key words: *potato tubers, impurities, experiments, calculations on the PC, parameters.*

DOI: <https://doi.org/10.31073/agrovisnyk202007-08>

One of the main problems in harvesting potatoes is cleaning the tubers from soil impurities and plant residues and reducing their loss and damage. The solution of this problem will ensure not only the quality of the products, but also exclude the removal of fertile soil from the fields. Therefore, the development of potato cleaners from impurities immediately after digging out the soil tuberous layer (potato tubers, soil impurities, as well as strong soil formations, roots, crop residues, stones, etc.) is an actual scientific and technical problem in the field of agricultural engineering.

We have developed a new construction of the potato spruce purifier, which consists of three cantilever drive spirals forming an active cleaning surface, on which the dug up spruce is fed (Fig. 1). In this case, it is possible to change the angle of inclination of the specified cleaning surface ensures the intensity of separation of impurities and guarantees the movement of tubers in the direction of the discharge elevator. All this also contributes to a better spreading of the heap over the cleaner's working surface, a more intensive destruction of soil clods, and therefore a better sifting of soil and plant impurities downstream of the cleaner and a reduction in clogging of the cleaning spirals. Ultimately, the cleaning efficiency and productivity of the potato cleaner from soil and plant impurities is improved.

Structurally, the spiral cleaner of potatoes from impurities consists of several (in this case three) driven cleaning spiral rollers 1, made in the form of spiral springs mounted cantilever, which form the working cleaning surface. On one side of this cleaning surface there is a loading elevator 2 and on the opposite side there is a discharge elevator 3. In addition, the upper part of the cleaning surface is provided with a flat protective screen 4 attached to the frame and a flat protective screen 5 attached to the side of the discharge elevator 3, which prevents the loss of potato tubers. Rollers 1 consist of mounted cantilever cleaning spirals with loose ends 6. The spirals themselves are mounted on hubs 7, which in turn are connected to drive shafts 8.

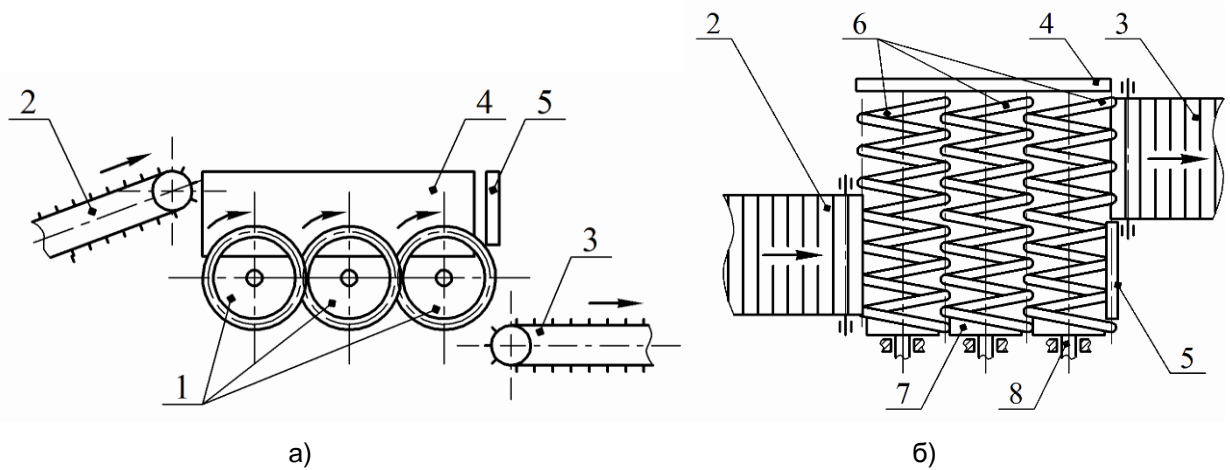

Fig. 1. Structural diagram of the potato cleaner of spiral type: a – side view; b – top view; 1 – Roller consisting of driven cleaning spirals; 2 – loading elevator; 3 – unloading elevator; 4, 5 – protective screens; 6 – cantilever ends of cleaning spirals; 7 – fixed ends of spirals; 8 – shafts, which drive the spirals into rotary motion

Cleaning spirals of rollers 1 have a mutual overlap. The entire cleaning surface formed by the roller cleaning spirals 1 has the possibility to change its position, i.e. to change the inclination angle to the horizon. The rotation of the three roller cleaning spirals 1, provided by the drive shafts 8, can be carried out at different angular speeds, so that the spiral coils can have different circular speeds. The rotation direction of roller cleaning spirals 1 is in one way. The roller cleaning spiral 1 itself is installed with mutual overlap, and its free ends 6 can make oscillating movements under the influence of variable loading of potato heap dug out of the soil, fed by the loading elevator 2.

This constructive solution of this potato spiral cleaner provides a large area of enlightenment on its cleaning surface, formed by the gaps between the windings of the most spirals and the gaps between the winding of the adjacent cleaning spirals. This increases the area through which impurities are separated outside the cleaner.

One of the advantages of this construction is that there are no shafts in the middle of each cleaning spiral to ensure that all impurities can flow down without hindrance and to prevent unwanted plant residues from being wound up in the spiral windings. The emptiness of the inner spaces inside each spiral allows to increase the ability to forcibly transport all the mass of soil and plant impurities to the original (cantilever) end of each spiral and to drop it through the free end on the surface of the field.

To prevent soil adhesion on the cleaning spirals and the gaps between the winding (during harvesting in wet soil), the spiral springs are installed with mutual overlap, where the windings of one spiral partially enter the gaps between the windings of the other spiral.

In order to ensure that the potato tubers move safely on the cleaning surface, it is possible to change the angle of the potato tubers. Each cleaning spiral has eccentricity, which allows it to carry out forced oscillating movements during the operation, which contribute to the mixing of the heap of heap supplied to it.

The purpose of the study. To substantiate the rational structural and kinematic parameters of the new spiral type potato heap purifier based on the results of multifactor field experimental study.

Methods of research. At performance of the given research methods of carrying out of field experimental researches, processing of the received data by means of the PC, correlation and regression analyses, and also methods of construction of nomograms are used.

The results of the research. Previously conducted experimental studies [1-3] to study the influence of the main structural and kinematic parameters of the spiral type potato cleaner from impurities on the percentage of sifted soil was found that among the parameters of the cleaner, which can affect the process of separation of soil and impurities, the greatest interest is the study of the influence of the angle α of the spirals of the cleaner to the horizon, the circumferential speed V of the rotational motion of the spirals, eccentricity of fixation of the spirals and the supply of Q on the purification spirals of the material, which is a heap of potato tubers dug out of the ground. Such constructive parameters of the cleaner as the spiral diameter ($D_s = 133$ mm), the angle of the spiral screw line ($\gamma_s = 12$ degree.), spiral bar diameter ($d_s = 11$ mm) are defined by us theoretically in previous studies [4, 8] and in this case they were taken as constant values.

For this study, a small-factor experiment of the species 2^{4-1} with repeatability of each experiment 3 was carried out [7]. The model, which was adopted to describe the influence of factors on the optimization parameter, was a linear function of the following species:

$$y = b_0 + b_1\alpha + b_2V + b_3\varepsilon + b_4Q, \quad (1)$$

where $b_0 \dots b_4$ – regression coefficients.

After conducting field trials and obtaining data from these experiments, they were processed on a PC using the Microsoft Excel 2003 application. The results of experimental data processing are presented in the form of regression equation, is a mathematical model of this process and links the parameters of the cleaning working body with the indicators of its work..

For the main indicator - the percentage of sifted soil, the regression equation is as follows:

$$Y1 = 118,396 + 0,25125\alpha - 12,2768V + 0,5325\varepsilon - 0,3175Q, \quad (2)$$

at multiple correlation coefficient $R = 0,6883634$, R -square = 0,780809, standard error 4.556817 and number of experiments that equal 8.

Relationship between optimization parameter, structural and kinematic parameters (factors) is characterized by the correlation coefficient. The correlation coefficient for the angle α of slope of the potato cleaner to the horizon is equal to

- 0.421541, for the circumferential speed V of the spirals 0.57674, for the eccentricity ε of the spirals fixing 0.4467, for the feed Q - 0.26635.

From the results of experimental data processing, it can be concluded that the greatest influence on the percentage $Y1$ of sifted soil is the circumferential speed V of spirals, a little less - eccentricity ε and the angle α of slope of the potato cleaner to the horizon. The smallest (with weak connection) has the feed rate Q . The "minus" sign before the coefficient indicates that with the growth of this factor the optimization parameter decreases. The angle α of the potato cleaner to the horizon and the material feed Q have this effect.

Therefore, further laboratory experimental studies investigated the effect of the circumferential speed V of the spirals and the angle α of slope of the potato cleaner on the percentage $Y1$ of sifted soil and the intensity of separation at constant values of the eccentricity ε of fixation of spirals and the supply Q of material to the spiral potato cleaner.

For this purpose, a full-factor experiment 3^2 with additional 4 points was implemented with a steady $20 \text{ kg}\cdot\text{s}^{-1}$ and fixing of spirals with 7 mm eccentricity.

Statistical processing of the experimental research results was carried out on PC using Microsoft Excel 2003 application.

The obtained experimental data were used for multivariate regression analysis using various types of functions [5].

The choice of the necessary function, on which it would be possible to carry out the multidimensional correlation analysis and to obtain an adequate mathematical model, was made by comparing the coefficients D of the multiple determination. Preference was given to the function with the highest value of this coefficient and it was a multidimensional polynomial of the second degree.

For this case (i.e. for the case of a multidimensional polynomial of the second degree) we carried out regression analysis for the selected type of function (Table). At the number of factors 2, variables 6, at the level of probability $P = 0,95$ (sufficiently high degree of reproducibility) and $t_\alpha = 2,176$ (critical Student coefficient) - for the polynomial of the second degree.

Results of regression analysis

Variable	Correlation	The linearized regression coefficient	Statistical error of the regression coefficient	t_α	Coefficient of elasticity	Significance of the regression coefficient
Dependent variable						
Y1		+67,2785				
Independent variables						
α	+0,719	- 0,1397	+0,18927	- 0,74	- 0,01	insignificant
V	- 0,555	+35,0949	+15,72361	+2,23	+0,79	significant
α^2	+0,578	- 0,0220	+0,00293	- 7,51	- 0,04	significant
$\alpha \cdot V$	+0,657	+0,4466	+0,08564	+5,21	+0,10	significant
V^2	- 0,563	- 11,7910	+3,75254	- 3,14	- 0,56	significant

After excluding an insignificant factor, the regression equation looks like this:

$$Y1 = 66,9523 + 34,7557 \cdot V - 0,0227 \cdot \alpha^2 + 0,3868 \cdot \alpha \cdot V - 11,566691 \cdot V^2, \quad (3)$$

while $D = 0,989$, $R = 0,994$, $s = 0,465$.

On the basis of the obtained regression equation with the help of PC and MathCad application the response surface of dependence of the sifted soil percentage Y_1 on the slope angle α of potato cleaner and circumferential speed V of its spirals was constructed (Fig. 2).

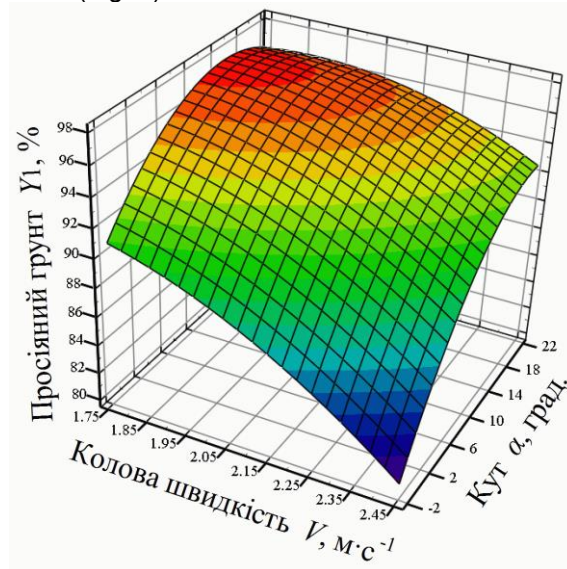

Fig. 2. Response surface to the influence of the potato cleaner's angle α of inclination to the horizon and the circumferential speed V of the rotational motion of the spiral on the percentage Y_1 of sifted soil

We studied the area of extremum by the method of two-dimensional sections. For this differentiated regression equation we studied the angle α of slope of the potato cleaner to the horizon and the circular velocity V of its spirals, respectively.

The obtained partial derivatives were equated to zero, and the following system of linear equations of this kind was obtained:

$$\left. \begin{aligned} \frac{dY_1}{d\alpha} &= -0,0454\alpha + 0,3868V = 0; \\ \frac{dY_1}{dV} &= 34,7557 + 0,3868\alpha - 23,13338V = 0. \end{aligned} \right\} \quad (4)$$

Having solved system of the equations (4), coordinates ($\alpha \approx 14,82$ degree., $V \approx 1,74 \text{ m}\cdot\text{s}^{-1}$) of points of a surface of the response in which function Y_1 reaches the maximum value $Y_1 \approx 97,4\%$.

Further the regression equation was reduced to a canonical form [6]. For this purpose the necessary characteristic equation is written down, it looks like:

$$K^2 + 11,5894K + 0,1659 = 0. \quad (5)$$

The result of the solution of this square equation is that $K_\alpha = -0,0144$, $K_V = -11,5751$.

As $|K_\alpha| < |K_V|$, the contour curves (ellipses) that correspond to the two-dimensional cross-sections of the response surface stretched along the α , axis are returned to the $\beta = 0,96 \text{ rad.} = 55 \text{ degrees.}$ from the V axis. Since the solutions of the characteristic equation are negative, the center of the ellipses is a point of maximum (Fig. 3).

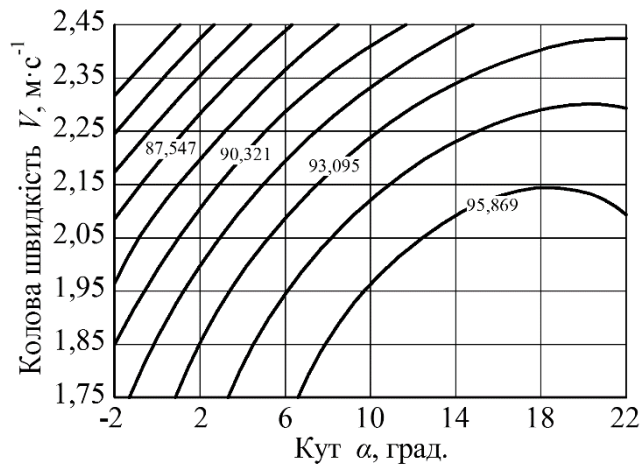

Fig. 3. Two-dimensional cross-section of the response surface to the influence of the potato cleaner's angle α of inclination to the horizon and the circumferential speed V of the spiral rotational motion on the percentage $Y1$ of sifted soil

Thus, on the basis of laboratory experimental studies the influence of such parameters of spiral separator as angle α of its inclination to the horizon, circumferential speed V of spirals, eccentricity ε of fixation of spirals and material feed Q on percentage $Y1$ of sifted soil was studied.

The obtained research results allowed to obtain a regression equation according to statistical data, adequately described, and all processes are reproducible. Sufficiently high values of the multiple correlation coefficient testify to the fact that the mathematical dependences (type of functions) chosen by us are consistent with the character of experimental dependences.

So, it is possible to make a conclusion that the received equations of regression can be used for exact definition of the parameter of optimization and optimum values of investigated factors.

On the basis of the obtained regression equations and certain optimal values of kinematic parameters, the response surface of the influence of material supply Q and the eccentricity ε of fixation of the potato cleaner spiral on the percentage $Y1$ of sifted soil at $\alpha = 14,85^\circ$ and $V = 1,74 \text{ m}\cdot\text{s}^{-1}$, is constructed as follows (Fig. 4).

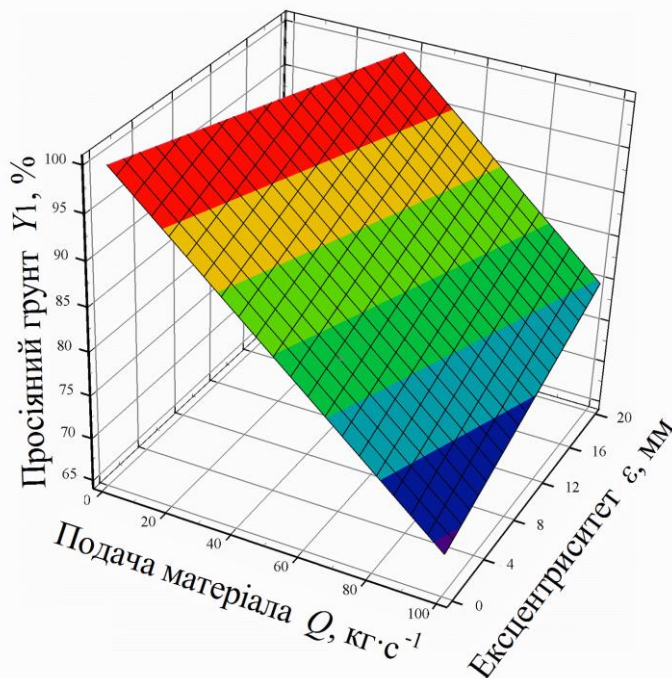

Fig. 4. Response surface of potato cleaner spiral feed Q and influence fixing eccentricity ε fixing the potato cleaner spiral by percentage $Y1$ of sifted soil at $\alpha = 14,85^\circ$ and $V = 1,74 \text{ m}\cdot\text{s}^{-1}$

The obtained empirical and graphical dependences, have a high level of correlation with the experimental data allow us to fully use the results of these studies to determine the optimal parameters of spiral separators of rhizomes in new constructions of cleaning machines.

Conclusions

We have developed a new construction of potato cleaner from impurities, it has an active cleaning surface, formed by drive spirals with cantilever ends, mutual eccentricity of fixation and possibility to change the angle of slope.

According to the data of the field experimental studies, a model of a full-scale experiment was built, the statistical processing of the results of which on a PC made it possible to carry out correlation and regression analyses of the obtained data using Microsoft Excel application.

The project was carried out in order to allow for the development of the structural and kinematic parameters for the purifier of spiral type potato houses, which can be used for the development of new potato harvesting machines.

References

1. Farhadi, R., Sakenian, N., & Azizi, P. (2012). Design and construction of rotary potato grader. *Bulgarian Journal of Agricultural Science*, 18, 304-314.
2. Wei, H., Wang, D., Lian, W., Shao, S., Yang, X., & Huang, X. (2013). Development of 4UFD-1400 Type Potato Combine Harvester. *Transactions of the Chinese Society of Agricultural Engineering*, 29(1), 11-17.
3. Ichiki, H., Nguyen, Van N., & Yoshinaga, K. (2013). Stone-clod separation and its application to potato cultivation in Hokkaido. *Biooriented Technology Research Advancement Institution, Engineering in Agriculture, Environment and Food*, 6(2), 77-85. doi: 16/s1881-8366(13)80030-4.
4. Grushetskiy, S., & Firman, Y. U. (2015). Issledovanie i obosnovanie parametrov lemeshno-otval'nogo kartofelekopatelya s barabannym separatorom kartofel'nogo vorokha. *MOTROL. Commission of Motorization and energetics in agriculture*, 17(1), 17-26.
5. Aniket, U., Dongre, Battase, R., Dudhale, S., Patil, V. R., & Chavan, D. (2017). Development of potato harvesting model. *International Research Journal of Engineering and Technology*, 4, 1567-1570.
6. Feng, B., Sun, W., Shi, L., Sun, B., Zhang, T., & Wu, J. (2017). Determination of restitution coefficient of potato tubers collision in harvest and analysis of its influence factors. *Transactions of the chinese society of agricultural engineering*, 33(13), 50-57.
7. Sibirev, A., Aksenov, A., Dorokhov, A., & Ponomare, A. (2019). Comparative study of force action of harvester work tools on potato tubers. *Research in Agricultural Engineering*, 65(3), 85-90. doi: 10.17221/96/2018-RAE.
8. Khamaletdinov, R. R., Martynov, V., Mudarisov, S., Gabitov, I., Khasanov, E., & Pervushin, A. (2019). Substantiation of rational parameters of the root crops separator with a rotating inner separation surface. *Journal of Agricultural Engineering*. doi: 10.4081/jae.2019.997.
9. Pat. № 43907 Ukraina, MPK (2006.01) A 01 D 33/08. Ochysnyk vorokhu korenebulboplodiv vid domishok. V. M. Bulhakov, P. Iu. Zikov, ta in.; zaiavnyk i patentovlasnyk Natsionalnyi ahrarnyi universytet. № u98073513. Zaiavl. 03.07.1998. Opubl. 15.01.2002. (2002). [Stalemate № 43907 Ukraine, IPC (2006.01) A 01 D 33/08. Purifier of heaps of root crops from impurities. V. M. Bulgakov, P. Yu. Zikov, etc.; applicant and patent owner National Agrarian university. № u98073513. Application 03.07.1998. 15.01.2002]. [In Ukrainian].
10. Bulgakov, V., Nikolaenko, S., Adamchuk, V., Ruzhylo, Z., & Olt, J. (2018). Theory of retaining potato bodies during operation of spiral separator. *Agronomy Research*, 16(1), 41-51.
11. Bulgakov, V., Pascuzzi, S., Nikolaenko, S., Santoro, F., Anifantis, A. Sotirios, & Olt, J. (2019). Theoretical study on sieving of potato heap elements in spiral separator. *Agronomy Research*, 17(1), 33-38.
12. Klindtworth, M. (2015). *Potato Technology*. Jahrbuch Agritechnik (Frerichs L. Edit.). (pp. 1-12).
13. Melnikov, S. V., Aleshkin, V. R., & Roshchin, P. M. (1980). *Planirovanie ehksperimenta v issledovaniyakh sel'skokhozyaystvennykh protsessov* [Experiment planning in research of agricultural processes]. Leningrad: Kolos. [In Russian].
14. Vasilenko, P. M., & Pogorely, L. V. (1985). *Basics of Research* [Fundamentals of scientific research]. Kiev: Higher school. [In Russian].
15. Nadykto, V. (2017). *Osnovy naukovykh doslidzhen* [Fundamentals of scientific research]. Kherson. [In Ukrainian].
16. Thornley, J. H. M., & France, J. (2007). *Mathematical models in agriculture: Quantitative methods for the plant, animal and ecological sciences*. Cabi.