

Forecasting quality of entomocultures

V. Lysenko,

Doctor of Technical Sciences

National University of Bioresources and Natural Resources of Ukraine

V. Belchenko,

Candidate of Technical Sciences

I. Chernova

Engineering and Technology Institute "Biotechnics" NAAS

The purpose. Determination of methodical approaches to prediction of quality of entomophages.
Methods. Experimental researches for kinds of *Trichogramma* *T. evanescens*, *T. pintoi*, *T. dendrolimi*, *T. semblidis* at the temperature of air in area of growth of 15°C, 20, 25, 27°C and relative humidity of air in area of growth of 80±5%. They studied probable fluctuations of parameters of entomophages. **Results.** It is offered to use a stability factor of homeostasis as an index of sustainability of entomophages to fluctuations of parameters of technical coenosis. According to probes the amount of females is the most stable parameter of assignment at fluctuation of temperature in area of growth of *Trichogramma*. **Conclusions.** Determination of the most stable parameters of entomophages to varying factors in conditions of technical coenosis will allow forecasting efficiency of their use in conditions of agrocenosis.

Key words: prediction, quality, entomophage.

Introduction. Getting an entomophages guaranteed quality in terms of technocenosis has a great deal meaningful for their effective use in the fight against pests in agrobiocenosis because of the requirements for environmental cleanliness of products food. Feature of entomophages insects is the use of living tissue or hemolymph another insect; by number of individuals consumed they are divided into parasites and predators. Now to the most common entomophages belong *Trichogramma*, *Chrysoperla carnea*, *Habrobrakon hebetor*, *Phytoseuilus*, *Aphidoletes aphidimyza*, *Aphidius*.

The prediction of the quality of entomocultures is conditioned by the need to reduce substandard products by systematizing the factors affecting quality. Well-known studies in the field of mass the production of entomocultures relates to: creation of favorable working conditions, improvement of feed quality [1, 2]; step-by-step control over the parameters of the production process [3]; shortening the breeding period; reducing the laboriousness of the breeding process; expansion of species composition; increase in output (viable adult species); reduction of morbidity and mortality; improvement of vital indicators (synchronicity of development, mass and productivity) [4]; a rational parasite-host ratio and the use of artificial nutrient medium [5]; optimization of spatial and age structures of artificial insect populations in the conditions of technocenosis [6]; preservation of the minimum level of diversity and functional stability of artificial populations [7]; forecasting the quality of entomoproduction with the help of a qualimetric approach [8]; methods of increasing viability and productivity [9]; reducing the cost of production by combining technological cycles several types of entomophages, which are supported on one type of feed. For example, predatory *Orius* and *Miridae* are breeding on a substitute the natural feed - the grain moth *Sitotroga cerealella*, which is a forage base for a wide range of entomophages (*Chrysoperla carnea*, *Coccinellidae*, *Podisus maculiventris*, *Trichogramma*) [10].

The purpose – determination of methodical approaches to prediction of quality of entomophages.

Results. On the one hand, the technocenosis is a set of hardware, providing microclimatic and other conditions, necessary for a stable existence and the development of entomoculture [11], on the other hand, a closed biotechnological ecosystem [12], which contains technological processes and associated

devices associated with material and energy flows, and is characterized by a complex multi-level structure of the interaction of processes of various nature (physical, biological, etc.) [13].

Technocenosis is a bounded set of indivisible technical products-individuals, connected by weak links [14] in space and time. In technocenosis operate the first and second laws of thermodynamics - conservation of energy and increasing entropy closed systems [14].

In the conditions of technocenosis there are [7]: a limited set of genotypes; a limited reduced natural selection effect; limited range of action of abiotic factors (cultivation of entomocultures is carried out in the optimum zone); increased population density due to limited area.

In fig. 1 is a descriptive model of technocenosis, where the input parameters are: x_1 - amount of raw material, x_2 - quantity of materials, x_3 - area for the location of equipment (shelves, vivariums, boxes, information controllers complexes, climatic installations, etc.), x_4 - electricity; destination options are: y_1 is the search activity, y_2 is the mass of caterpillars, y_3 - parasitism of host eggs; y_4 - emergence of imago, y_5 - the genital index (number of females), y_6 - fertility of females, y_7 - number of deformed individuals; the control parameters $u_1 - u_4$ are: feed amount, climatic conditions, duration of breeding offspring of the initial population, population density; uncontrolled parameters $z_1 - z_4$ are: loss of equipment operability, equipment wear, voltage variation in the electrical network, ambient temperature.

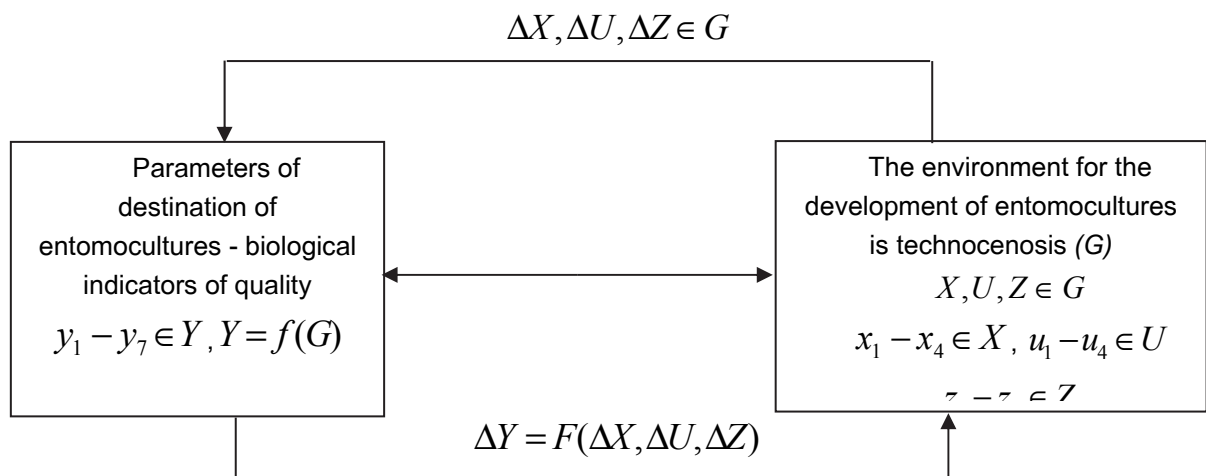

Fig. 1. Descriptive model of technocenosis

In fig. 2 shows the parametric model of technocenosis. Given that the technological process of production of entomocultures in the conditions of technocenoses by the nature of the determination is stochastic, and the destination parameters are random variables, then using the statistical test method Monte Carlo, using the mean (mathematical expectation) and the mean square deviation it is possible to estimate the probable changes in the biological quality indices entomocultures according to the experimental results research taking into account the influence of factors. Experimental studies were conducted in the laboratory of *Trichogramma* ITI "Biotechnics" for the species *T. evanescens*, *T. pintoii*, *T. dendrolimi*, *T. semblidis* at air temperature in the development zone of 15 °C, 20, 25, 27 °C and at relative humidity of air in the zone of development of $80 \pm 5\%$. So, when the temperature is changed by 2 °C, the average change value the emergence of *T. evanescens* with a probability of 95% is $9,94 \pm 0,56\%$; at 7 °C – $17,46 \pm 0,87\%$.

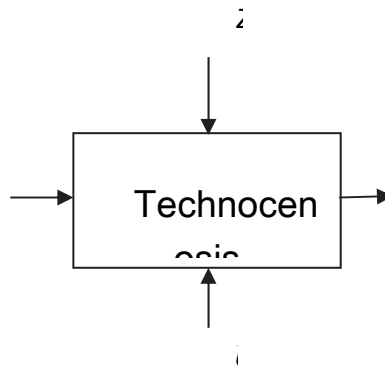

Fig. 2. Parametric model of technocenosis

$$Y = F(X, U, Z) \quad (1)$$

X - vector of input parameters

Y - vector of destination parameters

U - vector of control parameters

Z - vector of unmanaged parameters

In the case of a change in air temperature at 5°C is average the meaning of changing the number of females *T. evanescens* will be $2,99 \pm 0,07\%$.

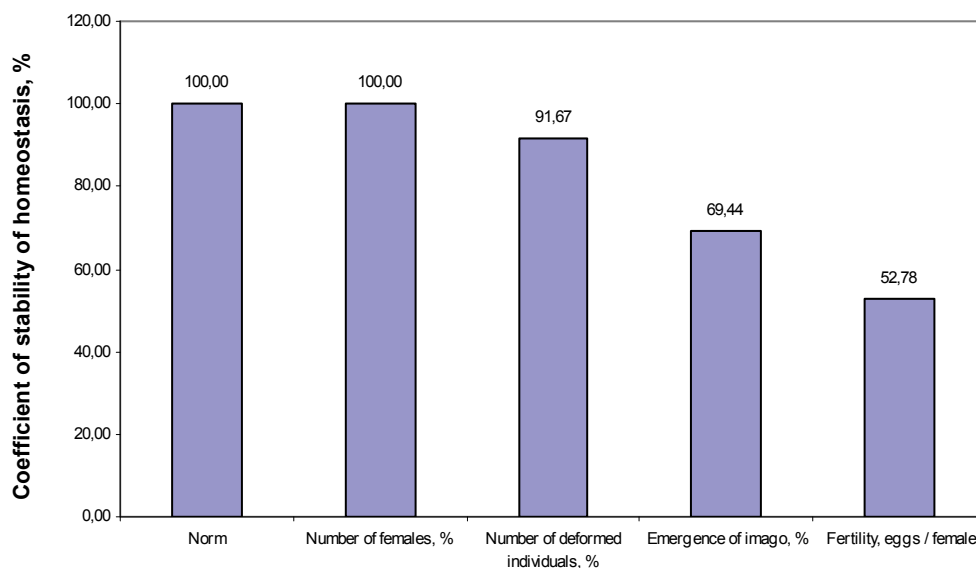

Fig. 3. Diagram of the significance of homeostasis stability coefficients for *Trichogramma*

The basis of stable functioning of biological systems is the maintenance of homeostasis at all levels of the organization of living matter [7]. Using the coefficient of stability of homeostasis as an indicator of the constancy of entomophages to change the technocenosis parameters [15], it is possible to predict the quality of entomocultures by the results of experimental studies. Calculated (in percent) homeostasis stability factor as a ratio of the number of indicators that meet the norm, to the total number of investigated indicators [16]. Yes, in fig. 3 shows a diagram of the significance of homeostasis stability coefficients for such indicators quality of *Trichogramma*, as the emergence of imago, the number of deformed individuals, the number of females, fertility in the temperature range in the development zone

from 15 to 27°C. The analysis of the diagram shows that the number of females is the most stable parameter in case of temperature change in the zone of development of *Trichogramma*.

Conclusions

Application of the method of Monte Carlo statistical tests with probability 0,95 makes it possible to predict the quality of entomocultures in the conditions of technocenosis at changes in abiotic, biotic and technological factors of influence. Depending on the purpose of breeding set the rigid the requirements for the quality of entomocultures, which is formed by a step-by-step integrated action regulated factors of influence and is related to the accuracy and stability of them maintenance by means of automated control systems. Determination of the most stable of parameters destination of entomocultures to change the factors in the conditions of technocenosis will enable to predict their effective use in conditions of agroecocenosis.

Bibliography

1. Molchanova E.D., Leshishak A.V., Sheykina E.B. Effect of feed substrate for rearing caterpillars mill moth on the biological performance of bracon. Mater.VI Intern. scientific. conf. Readings in memory of professor I.I. Barabash - Nikiforov, VSU, March 25, 2014 – Voronezh, VSU, 2014. – P. 105-108.
2. Molchanova E.D., Sheykina E.B., Gorodetsky S.A. Optimization of fodder for growing a mill moth. Scientific-practical Center of the NAS of Belarus for agriculture. Collection of scientific works "Protection of plants." - 2015. - Vol. 39. - P. 191 - 196.
3. Krasavina L.P. Optimization of the breeding process *Aphidius kolemani*. Protection and plant quarantine. - 2009. - Vol. 1. - P. 39 - 42.
4. Panova R.I. Increase of effectiveness of hydroponic vegetable growing with the use of ultrasound in biological plant protection: the dissertation abstract for the degree of Cand. of techn. sciences: 05.20.02 (protection in Chelyabinsk, 2015). - 156 p.
5. Demyanchuk N.P. Biotechnological aspects of manufacture entomological preparation of *Trichogramma* (HYMENOPTERA, TRICHOGRAMMATIDAE) for biological plant protection: the dissertation abstract for the degree of Cand. of agricultural sciences: 03.00.20, protection 06.12.2007 year / N.P. Demyanchuk. - K., 2007. - 25 p.
6. Markina T.Yu., Bachinskaya Ya.A., Kalinina O.V. Spatial optimization and age structures of artificial populations insects in the conditions of technocenoses. Biodiversity and Role of Zoocenosis in Natural and Anthropogenic Ecosystems: Extended Abstracts of the Second International Conference. – Dnipropetrovsk: Dnipropetrovsk National University, 2003. - P. 133-135.
7. Markina T. Yu. Structural features of artificial populations of insects as a basis of their functional stability. The Kharkov Entomological Society Gazette 2007 (2008). - Vol. XV, issue 1–2. – P. 197-200.
8. Barabash A.D., Chernova I.S., Leshishak A.V., Dolzhikova I.V. Forecasting of quality cultures of insects in iterative technological processes manufactures of insects. Bulletin of the Agrarian Science of the Southern Region, 2014. - Vol. 1. – P. 65-69.
9. Leshishak A.V. Ways to improve viability and the performance of the entomophage of *Trichogramma*. Bulletin of the Agrarian Science of the Southern Region, 2014. - Vol. 1. – P. 121-127.
10. Belyakova N.A. Features of modern technology mass breeding of entomophages. Plant protection and quarantine, 2010. - Vol. 8. – P. 18-20.
11. Industrial entomology. Terms and conditions definition of concepts. State standard of Ukraine 4757:2007. - Active with 01. 01.2009. – Kiev, 2010. – 20 p.
12. Zlotin A.Z. Technical entomology: Reference allowance. – Kiev, Scientific thought, 1989. – 183 p.
13. Sheikin B.M., Belchenko V.M., Besspalov I.N., Sheykina E.B. Biotechnological systems in industrial entomology. Scientific-practical Center of the NAS of Belarus for agriculture. Collection of scientific works "Protection of plants." - 2014. - Vol. 38. - P. 245-250.
14. Gnatyuk V.I. The law of optimal construction of technocenoses: monograph. Kaliningrad: KPC «Technocenosis», 2014. - 204 p.

15. Chernova I.S. Methodological approaches to quality management of entomophages. Machinery and Technologies for Agro-industrial Complex, 2016. - Vol. 77, issue 2 (77). – P. 32-33.
16. Antonov A.R. Systemic assessment of violations homeostasis in critical conditions. Modern problems of science and education. –Novosibirsk: Novosibirsk State Medical University, 2009. - Vol. 6. - P. 8.